

STRUCTURALLY CERTIFIED

ITEM No.	QTY.	DESCRIPTION	MATERIAL OPTIONS
1	1	TOP POLE SECTION - PLAIN	STEEL / HOT-DIP GALVANIZED
2	1	Maxis™ M2 JOINT	STEEL / HOT-DIP GALVANIZED
3	1	BASE POLE SECTION	STEEL / HOT-DIP GALVANIZED

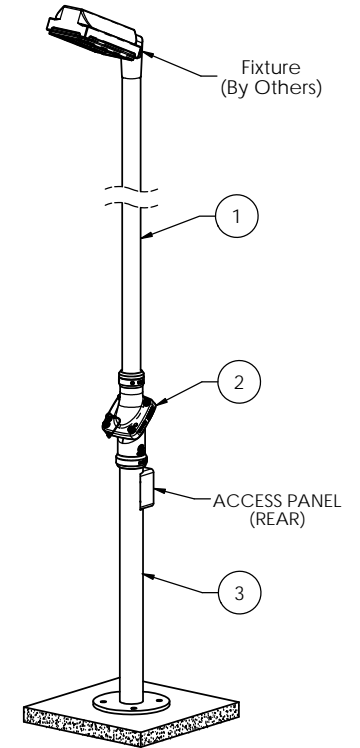
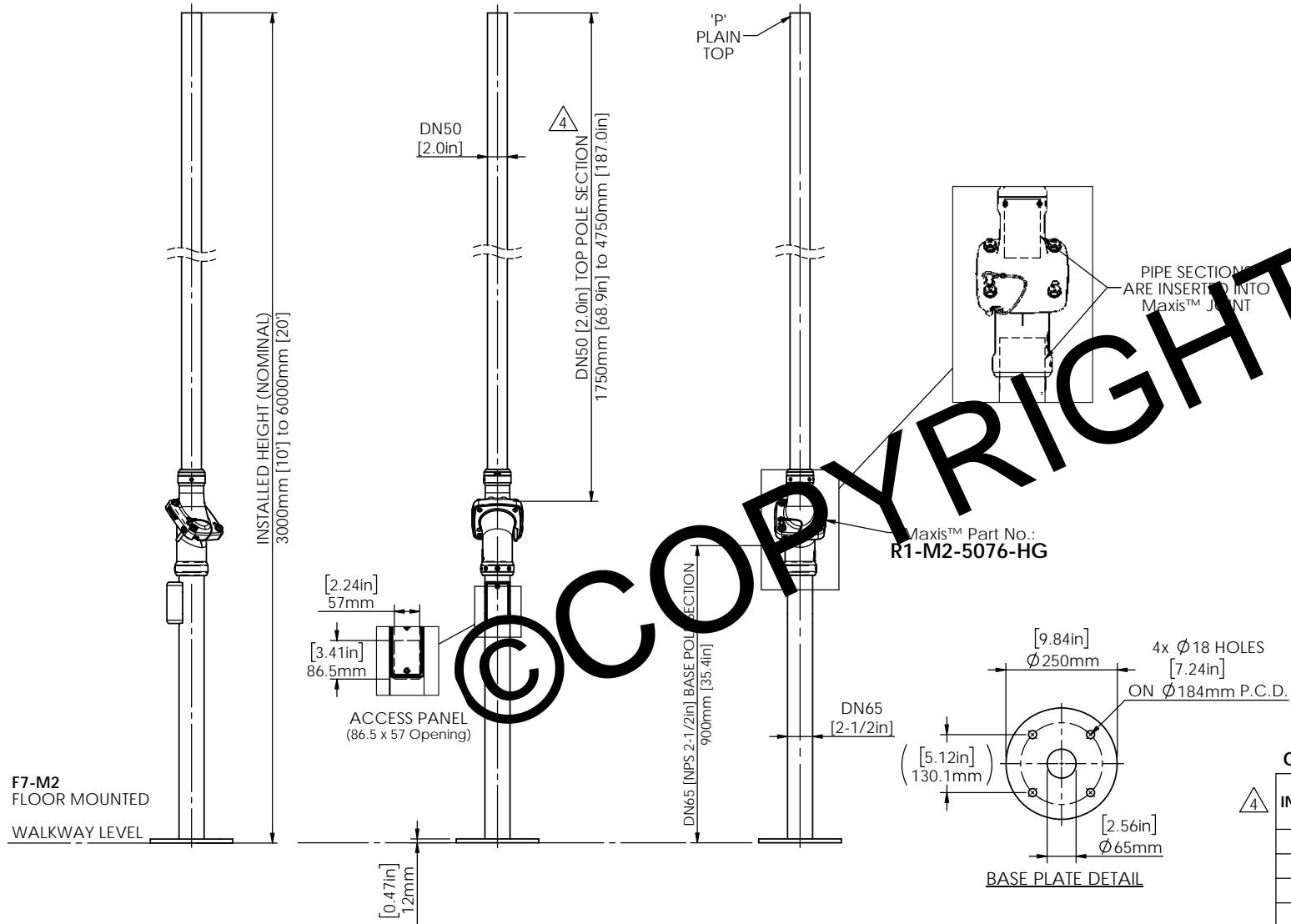

F7-M2 - FLOOR MOUNTED
TYPICAL ASSEMBLY

Ordering Information: HOT-DIP GALVANIZED

INSTALLLED HEIGHT	PRODUCT CODE	WEIGHT	MAX EQUIPMENT WEIGHT
3000mm [10']	F7-M2-3000-P-HG	24.2 kg (53.2 lb)	20.0 kg (44.0 lb)
4000mm [13']	F7-M2-4000-P-HG	28.3 kg (62.3 lb)	15.0 kg (33.0 lb)
5000mm [16.5']	F7-M2-5000-P-HG	32.4 kg (71.3 lb)	10.0 kg (22.0 lb)
6000mm [20']	F7-M2-6000-P-HG	36.5 kg (80.3 lb)	7.0 kg (15.4 lb)



Scan Code with QR Reader app for more Maxis™ Product Solutions

maxis
PATENTED PRODUCTS

www.maxisjoint.com

PATENTED PRODUCTS

www.swivelpole.com

swivelpole

This document is the property of and protected by copyright owned by Swivelpole Group Pty Ltd and/or Exemplar Products Pty Ltd. The designs and other information embodied in this document comprise confidential information of Swivelpole Group Pty Ltd and/or Exemplar Products Pty Ltd and form part of products covered by international patents and registered designs including US patent No 6957832 and US patent No 9945143. Unauthorised use, reproduction and disclosure are strictly prohibited. This document must not be removed from the premises of the licensed user of this document without Swivelpole Group Pty Ltd's and/or Exemplar Products Pty Ltd's prior approval.

ALL DIMENSIONS ARE IN MILLIMETERS / INCHES	SERIES / CODE	PART NUMBER
	F	As Noted (RQ1916 - 21/09/23)
DRAWN BY: BP	DATE: 29/09/20	TITLE: Swivelpole™ F7 - Maxis™ M2
CHECKED BY: KM	DATE: 30/09/20	Base Section cw Access Panel - Top Section - PLAIN
APPROVED BY: AI	DATE: 30/09/20	General Assembly
THIRD ANGLE PROJECTION	SCALE: N.T.S.	DRG No: C-IEC-F7-M2-6550-P-HG
		REV: 4
		A3

IEC