

STRUCTURALLY CERTIFIED

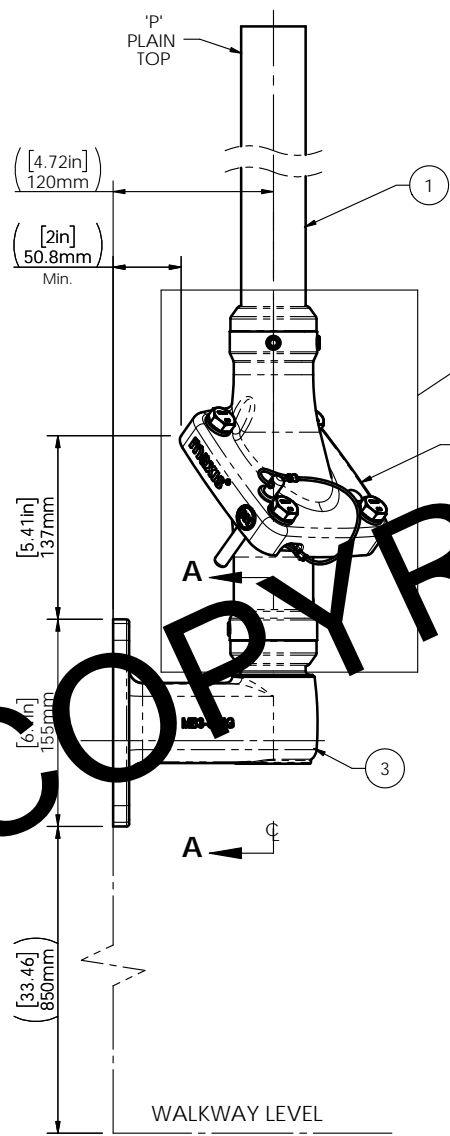

ITEM No.	QTY.	DESCRIPTION	MATERIAL OPTIONS
1	1	TOP POLE SECTION - PLAIN	STEEL / HOT-DIP GALVANISED ALUMINIUM
2	1	Maxis™ M1 JOINT	STEEL / HOT-DIP GALVANISED
3	1	Swivelpole™ MB3-S-HG MOUNTING BRACKET	STEEL / HOT-DIP GALVANISED

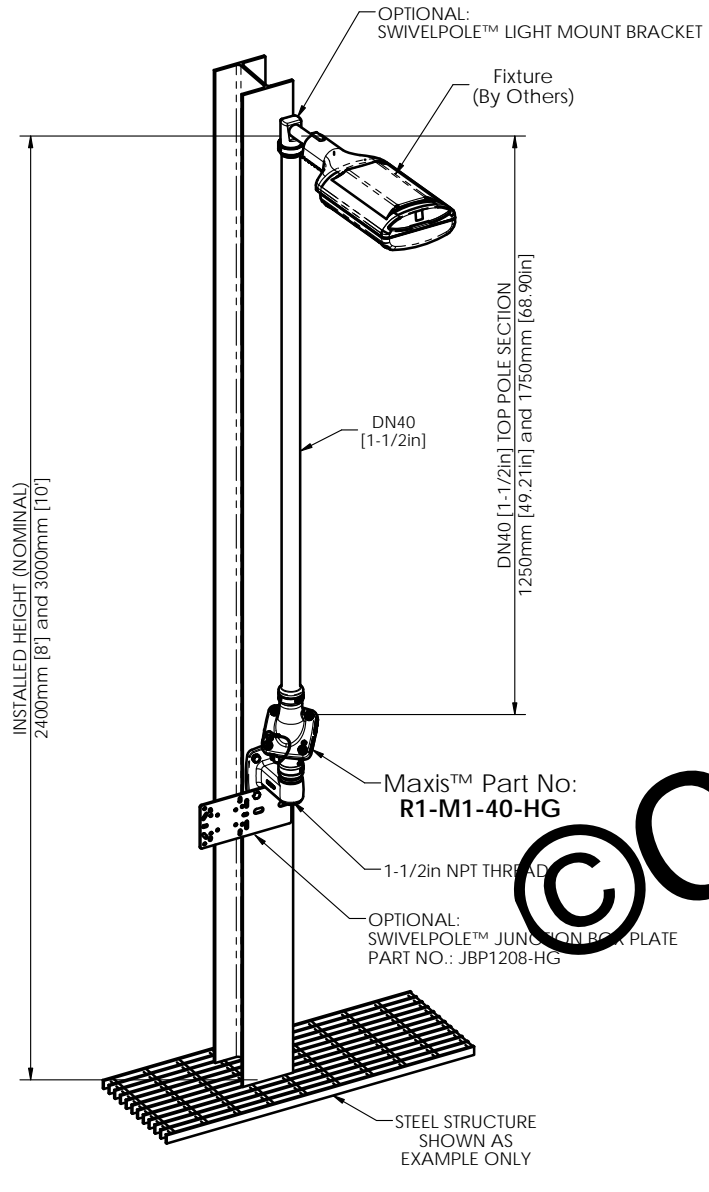
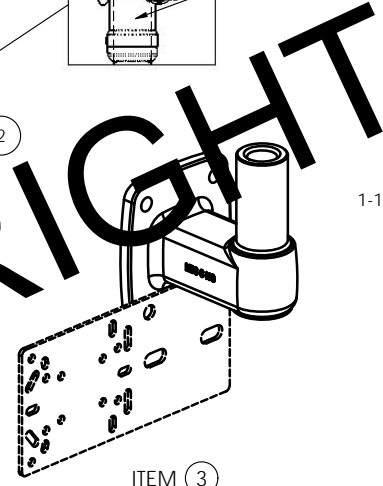
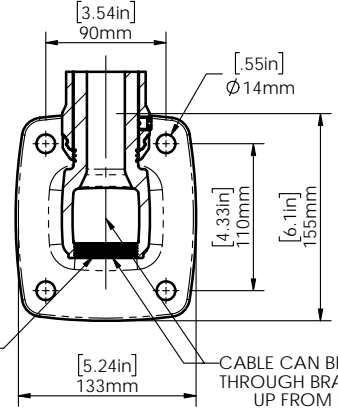
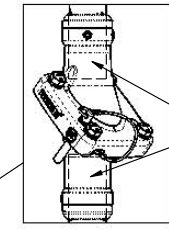

COPYRIGHT

Ordering Information: ALUMINIUM

INSTALLED HEIGHT	PRODUCT CODE	WEIGHT
2400mm [8']	C1-M1-2400-P-HG-AL	10.8 kg (23.8 lb)
3000mm [10']	C1-M1-3000-P-HG-AL	11.6 kg (25.5 lb)

Ordering Information: HOT-DIP GALVANISED

INSTALLED HEIGHT	PRODUCT CODE	WEIGHT
2400mm [8']	C1-M1-2400-P-HG	13.1 kg (28.8 lb)
3000mm [10']	C1-M1-3000-P-HG	14.9 kg (32.8 lb)

C1-M1 - COLUMN / WALL MOUNTED TYPICAL ASSEMBLY



Scan Code with QR Reader app for more Swivelpole™ Solutions

maxis
PATENTED PRODUCTS
www.maxisjoint.com

PATENTED PRODUCTS
www.swivelpole.com

Swivelpole™

This document is the property of and protected by copyright owned by Swivelpole Group Pty Ltd and/or Exemplar Products Pty Ltd. The designs and other information embodied in this document comprise confidential information of Swivelpole Group Pty Ltd and/or Exemplar Products Pty Ltd and form part of products covered by international patents and registered designs including US patent No 6957832 and US patent No 9945143. Unauthorised use, reproduction and disclosure are strictly prohibited. This document must not be removed from the premises of the licensed user of this document without Swivelpole Group Pty Ltd's and/or Exemplar Products Pty Ltd's prior approval.

ALL DIMENSIONS ARE IN MILLIMETERS / INCHES	SERIES / CODE C	PART NUMBER As Noted	(R01911 - REV 5 - 22/08/23)
DRAWN BY BP	DATE 05/04/19	TITLE Swivelpole™ C1 - Maxis™ M1 MB3 Bracket, Top Section - PLAIN General Assembly	
CHECKED BY KM	DATE 08/04/19		
APPROVED BY AI	DATE 08/04/19		
THIRD ANGLE PROJECTION	SCALE N.T.S.	DRG No C-IEC-C1-M1-4040-P-[HG-AL]	REV 5

IEC