

MBK9-002-HG
TYPICAL INSTALLATION
 ALSO SUITS SWIVELPOLE™ ST4-M1 & ST4-M2

SWIVELPOLE™
 ST7-M2
 ASSEMBLY



Scan Code with
 QR Reader app
 for more Maxis™
 Product Information

SWIVELPOLE SUPPLIED
 M16 FASTENER KIT
 P/No: M16FSNK-004-HG

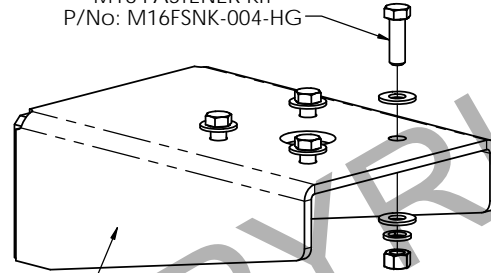

MB9-002-HG
 BRACKET

ISO VIEW

PART NUMBER = MBK9-002-HG

MATERIAL = Steel HDG Finish
 WEIGHT = 19.0 kg

**MOUNTING BRACKET SUITABLE
 WITH ALUMINIUM**

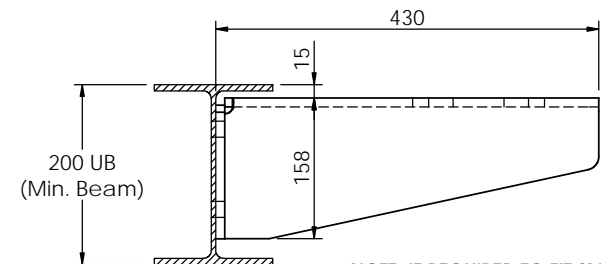
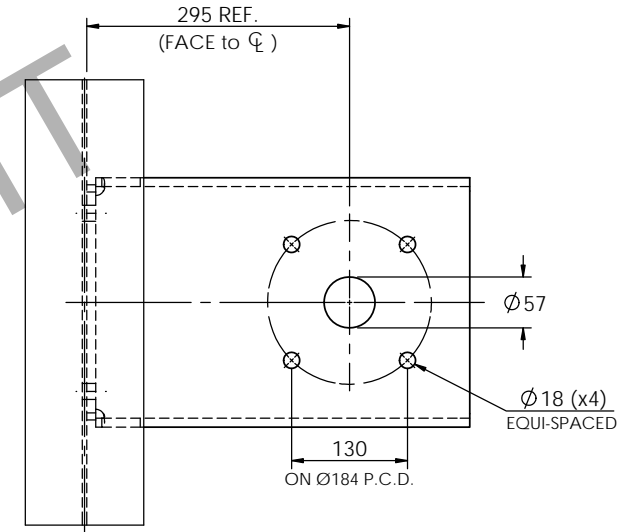
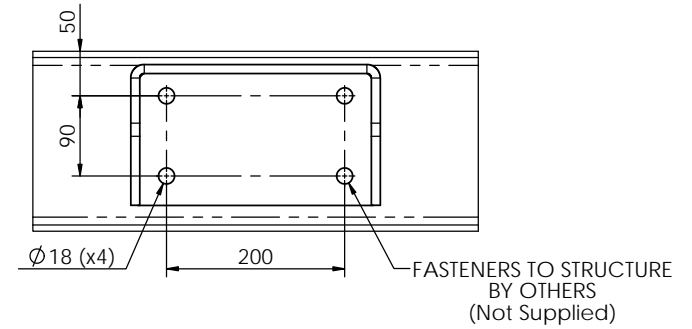

NOTE: IF REQUIRED TO FIT SMALLER
 BEAM SECTION, CONTACT SWIVELPOLE
 FOR ALTERNATIVE MB9 OPTIONS.



Scan Code with
 QR Reader app for more
 Swivelpole™ Solutions

maxis
 PATENTED
 PRODUCTS

www.maxisjoint.com

PATENTED
 PRODUCTS

www.swivelpole.com

Swivelpole

This document is the property of and protected by copyright owned by Swivelpole Group Pty Ltd and/or Exemplar Products Pty Ltd. The designs and other information embodied in this document comprise confidential information of Swivelpole Group Pty Ltd and/or Exemplar Products Pty Ltd and form part of products covered by international patents and registered designs including US patent No 6957832 and US patent No 9945143. Unauthorised use, reproduction and disclosure are strictly prohibited. This document must not be removed from the premises of the licensed user of this document without Swivelpole Group Pty Ltd's and/or Exemplar Products Pty Ltd's prior approval.

ALL DIMENSIONS ARE IN MILLIMETERS	SERIES / CODE MB	PART NUMBER MBK9-002-HG	DRG No C-AU-MBK9-002-HG
DRAWN BY BP	DATE 18/03/16	TITLE Swivelpole™ Mounting Bracket MB9 Outrigger Bracket for ST Series General Assembly	REV 4
CHECKED BY KM	DATE 18/03/16		A3
APPROVED BY RP	DATE 18/03/16		
THIRD ANGLE PROJECTION	SCALE N.T.S.		