

**PART NUMBER = LMK5129-50-HG**

MATERIAL = Steel - HDG Finish

WEIGHT = 1.0 kg

SUPPLIED WITH 1x DN50 U-BOLT KIT

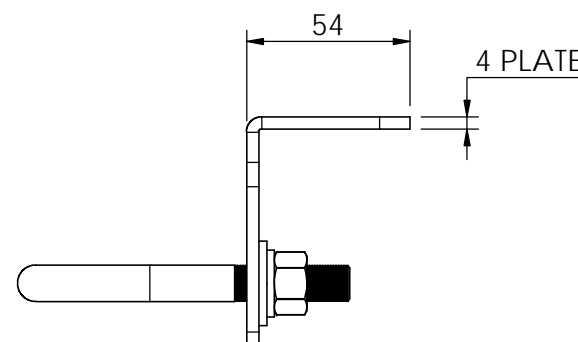

Scan Code with QR Reader app for more Swivelpole™ Light Mount Product Information

**PATENTED**  
PRODUCTS

[www.swivelpole.com](http://www.swivelpole.com)

**Swivelpole™**

This document is the property of and protected by copyright owned by Swivelpole Group Pty Ltd. The designs and other information embodied in this document comprise confidential information of Swivelpole Group Pty Ltd and form part of products covered by international patents and registered designs including US patent No 6957832. Unauthorised use, reproduction and disclosure are strictly prohibited. This document must not be removed from the premises of the licensed user of this document without Swivelpole Group Pty Ltd's prior approval.

ALL DIMENSIONS ARE IN MILLIMETERS	PROJECT	SERIES / CODE	PART NUMBER
	SWIVELPOLE™	LMK	LMK5129-50-HG (TQ2500)
DRAWN BY	BP	DATE	07-11-18
CHECKED BY	KM	DATE	08-11-18
APPROVED BY	AI	DATE	08-11-18
THIRD ANGLE PROJECTION	SCALE		DRG No
	1:2.5		C-AU-LMK5129-50-HG
		REV	A3
		0	

TITLE  
DN50 (Ø60.3) Luminaire Mount  
Multi-Fit Mounting Plate - Floodlight Mount  
Client Detail